

FA4™ FA9TE

FLANGE
ALIGNMENT
TOOLS



CONTENTS

1. INTRODUCTION
2. TOOL SAFETY
 - 2.1 GENERAL SAFETY
 - 2.2 PERSONNEL COMPETENCY
 - 2.3 DISCLAIMER
 - 2.4 DEFINITION OF TERMS
 - 2.5 HAZARDS
3. FLANGE MISALIGNMENT DETERMINATION PROCEDURE
 - 3.1 LATERAL MISALIGNMENT
 - 3.2 ROTATIONAL (TWIST) MISALIGNMENT
4. FA4TM MECHANICAL FLANGE ALIGNMENT TOOL
 - 4.1 TOOL CAPABILITIES
 - 4.2 RANGE OF APPLICATION
 - 4.3 TOOL FUNCTION
 - 4.4 KIT CONTENTS
 - 4.5 TOOL DIMENSIONS
 - 4.6 TOOL MAINTENANCE
5. FA9TE HYDRAULIC FLANGE ALIGNMENT TOOL
 - 5.1 TOOL CAPABILITIES
 - 5.2 RANGE OF APPLICATION
 - 5.3 TOOL FUNCTION
 - 5.4 TOOL DIMENSIONS
 - 5.5 TOOL MAINTENANCE
6. RANGE OF APPLICATION
 - 6.1 BS10, API6BX, API6B WELD NECK FLANGE TABLES
 - 6.2 ASME B16.5, ASME B16.47, DIN WELD NECK FLANGE TABLES
 - 6.3 SPO FLANGE TABLE
7. TROUBLESHOOTING
 - 7.1 FA4TM TROUBLESHOOTING
 - 7.2 FA9TE TROUBLESHOOTING
8. REGULATORY INFORMATION
 - 8.1 REGISTERED HEAD OFFICE
9. PARTS LISTS & SERVICE KITS

27/04/2017

1.

INTRODUCTION

The Equalizer™ FA4TM and FA9TE Flange Alignment Tools are aids for use in normal maintenance and installation procedures, and enable the realignment of misaligned flanges within their respective working capacities.

For example, the tools can be used to assist in the replacement of ring and other types of flange joint.



It is essential that the user familiarises themselves with the contents of this manual prior to using the tool.

This manual contains information for the following tools:

- FA4TM Flange Alignment Tool
- FA9TE Flange Alignment Tool

2.

SAFETY INFORMATION

2.1

GENERAL SAFETY

These instructions cover the safe operation and maintenance of THE EQUALIZER **FA4TM** and **FA9TE** FLANGE ALIGNMENT tools. The use of these tools should be as part of a broader task-based risk assessment, which should be carried out by the operation supervisor or other competent person.

Failure to comply with the safety information contained within this manual could result in personal injury or equipment damage. Read all instructions, warnings and cautions carefully, and follow all safety precautions.

The safety of the operator, any assisting personnel and the general public is of paramount importance. Always work in accordance with applicable national, local, site & company-wide safety procedures.

2.2

PERSONNEL COMPETENCY

Only personnel deemed competent in the use of mechanical and hydraulic equipment should use these tools.

2.3

DISCLAIMER

Equalizer cannot be held responsible for injury or damage resulting from unsafe product use, lack of maintenance or incorrect product and/or system operation. If in doubt as to the safety precautions and applications, contact Equalizer using the contact details at the back of this manual.

2.4

DEFINITION OF TERMS

A **CAUTION** is used to indicate correct operating or maintenance procedures and practices to prevent damage to, or destruction of equipment or other property.

A **WARNING** indicates a potential danger that requires correct procedures or practices to avoid personal injury.

A **DANGER** is only used when your action or lack of action may cause serious injury or even death.



DO: an illustration showing how the tool should be used.



DON'T: an illustration showing an incorrect way to use a tool.

2.5

HAZARDS



WARNING: ensure all hydraulic components are rated to a safe working pressure of 700 bar (10 000 psi).



WARNING: Do not overload equipment. The risk of hydraulic overloading can be minimised by using the Equalizer Hand Pump, which has a factory-set safety valve preventing the safe working pressure being exceeded.

If alternative hydraulic pumps are used, ensure that there are adequate systems to limit the working pressure to 700 bar (10 000 psi).



CAUTION: ensure components are protected from external sources of damage, such as excessive heat, flame, moving machine parts, sharp edges and corrosive chemicals.



CAUTION: Take care to avoid sharp bends and kinks in hydraulic hoses. Bends and kinks can cause severe back-up pressure and cause hose failure. Protect hoses from dropped objects; a sharp impact may cause internal damage to hose wire strands. Protect hoses from crush risks, such as heavy objects or vehicles; crush damage can cause hose failure.



WARNING: Applying pressure to a damaged hose may cause it to rupture.



WARNING: Immediately replace worn or damaged parts. Use only genuine Equalizer parts from approved distributors or service centres. Equalizer parts have been engineered and manufactured to be fit-for-purpose.



DANGER: To minimise risk of personal injury keep hands and feet away from the tool and workpiece during operation.



WARNING: Always wear suitable clothing and Personal Protective Equipment (PPE). Do not handle pressurised hoses; escaping oil under pressure can penetrate the skin, causing serious injury. Seek medical attention immediately if oil penetration is suspected.



WARNING: Only pressurize complete and fully connected hydraulic systems. Do not pressurize systems that contain unconnected couplers.



CAUTION: Do not lift hydraulic equipment by the hoses or couplers. Use only the designated carrying handles.



CAUTION: Lubricate tools as directed in this manual prior to operation. Use only approved lubricants of high quality, following the lubricant manufacturers instructions.



CAUTION: Only use the designated anchor point for fixing the lanyard. Do not attach the lanyard to the plastic handle.



DANGER: Care should be taken when using the lanyard to avoid entanglement with body parts.



The vibration total value to which this tool is subjected does not exceed 2.5 m/s².

3.

FLANGE MISALIGNMENT DETERMINATION PROCEDURE

The tool being used must not be attached to a flanged joint prior to the misalignment procedure being carried out.

3.1 LATERAL MISALIGNMENT

1. Loosen and remove every second bolt around the flange. Continue with this until misalignment occurs.

A flanged joint, once broken down, may spring out of alignment at any point or in any direction around its circumference. Misalignment may not occur until only a few bolts remain.

2. At this point the direction of any misalignment should become obvious. The alignment tool being used should be attached at the maximum point of misalignment (point A or B in the examples shown below).

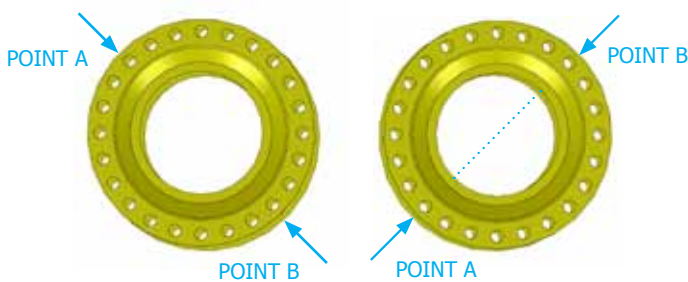

3.2 ROTATIONAL (TWIST) MISALIGNMENT

If the outer circumference of the flanges are in alignment but the operator is unable to fit the bolt into any two corresponding bolt-holes then rotational misalignment may have occurred.

In this case the alignment tool can be attached to the most accessible point as misalignment occurs at all bolt-holes to the same degree.

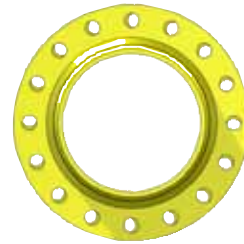

1. Attach the alignment tool at the most accessible/convenient point (as shown in sections) and use it to push the flanges out of alignment until one pair of bolt-holes becomes parallel.

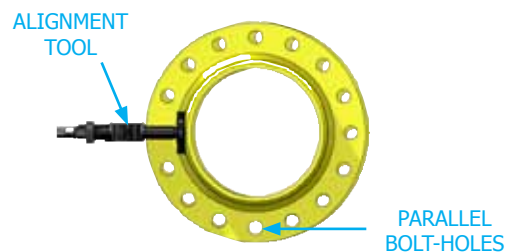

2. Insert the bolt into the aligned bolt-hole and release the alignment tool. The load will transfer onto the bolt.

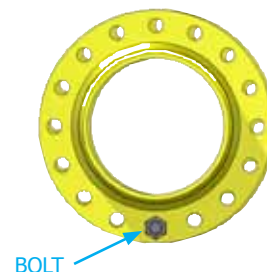

3. Repeat steps 1 and 2 at other points around the flange until all of the remaining bolt-holes are parallel and the rest of the bolts can be inserted.

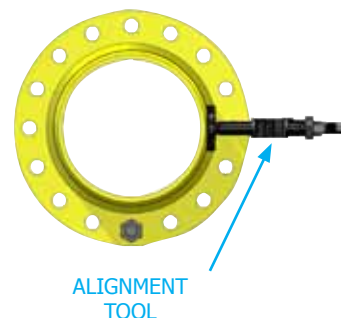

4.

FA4TM

MECHANICAL FLANGE ALIGNMENT TOOL

The FA4TM Flange Alignment Tool uses mechanical torque to advance the screw bolt and align the flanges.



4.1 TOOL CAPABILITIES

ALIGNING FORCE

Maximum SWL torque of 68 N·m (50 ft·lb) will generate 4 T (40 kN) aligning force.

4.2 RANGE OF APPLICATION

Minimum and Maximum Flange sizes:

Dimension A: must be between 30 mm and 133 mm (1.18" and 5.23")

Dimension B: bolt-hole diameter must be 24 mm (0.94") or greater

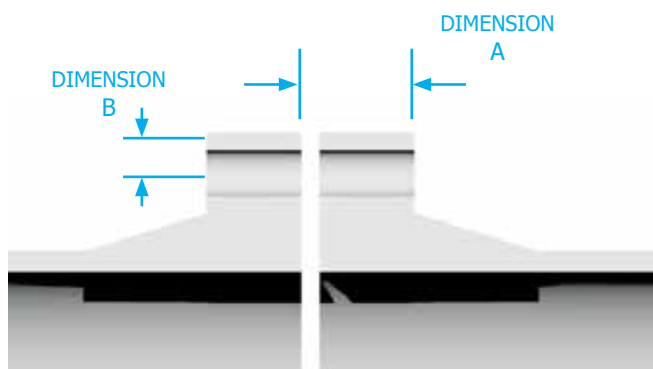

4.3 FA4TM TOOL FUNCTION

MECHANICAL TOOL OPERATION

The FA4TM Alignment tool uses mechanical torque to advance the screw bolt and align the flanges. The torque is applied using the supplied Torque Wrench, enabling accurate control of the force applied.



TORQUE WRENCH USAGE

Holding the Torque Wrench in one hand, unlock the knurled handle by turning the locking knob anti-clockwise.

Select the torque setting by turning the knurled handle until the required torque value is indicated.

For example, to set the Torque Wrench to 46 N·m: turn the knurled handle until the 0 on the fine scale aligns with 40 N·m on base scale; now turn slightly further until the 6 on the fine scale aligns with the central line.



Setting an imperial torque (in ft·lb) is done in exactly the same way.

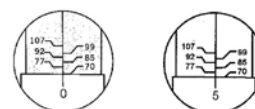

Lock the handle by turning the locking knob clockwise. Do not attempt to turn the grip while it is locked.

Install the supplied socket onto the Torque Wrench and attach to the tool.

Slowly and smoothly pull the handle, gradually applying more force until you feel or hear the Torque Wrench click, indicating that the selected torque has been achieved. Do not continue to apply force after the Torque Wrench has clicked. Special care should be taken when using low torque settings.

TORQUE WRENCH CARE

Prior to storing the Torque Wrench, and between use, leave the Torque Wrench with its lowest torque setting selected.

To clean the Torque Wrench, wipe gently with a damp cloth. Avoid using any detergent or solvent as this may detrimentally affect the factory-fitted internal lubrication of the mechanism.

FA4TM GENERAL GUIDANCE

The FA4TM is secured to the lower of the two flanges by fully inserting the lift hook into the bolt-hole at the point of greatest misalignment.

The dop leg is adjusted down to the pipe while the tool is held level in the bolt-hole.

The wing retaining screw is loosened to allow the wing to be extended out.

The screw bolt is turned clockwise until the friction pad comes into contact with the circumference of the opposite flange.

The torque wrench is set to 68 N·m (50 ft·lb) (max), attached to the screw bolt and turned to screw down the flange, bringing the joint into alignment.

ACTUATING THE FA4TM

Carry out the Flange Misalignment Determination Procedure (see Section 3) to determine the points of maximum misalignment.

In this example the points of maximum misalignment are the top and bottom of the joint.

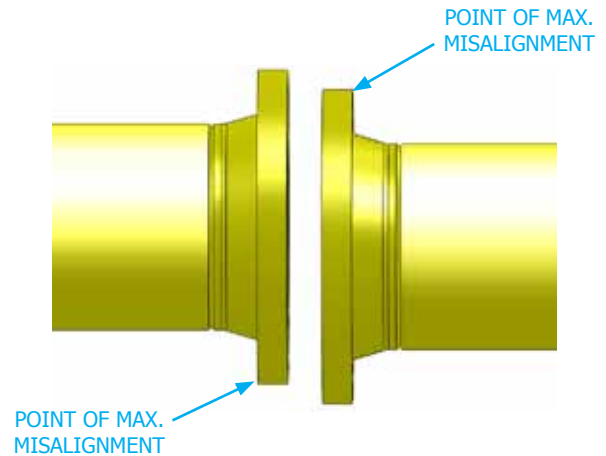

Guide the lift hook into the bolt-hole at the maximum point of misalignment.

Adjust the drop leg down onto the pipe by turning the adjustment knob in a clockwise direction. The tool should be held up level within the bolt-hole during adjustment.

N.B. The tool must be parallel to the pipe at all times.

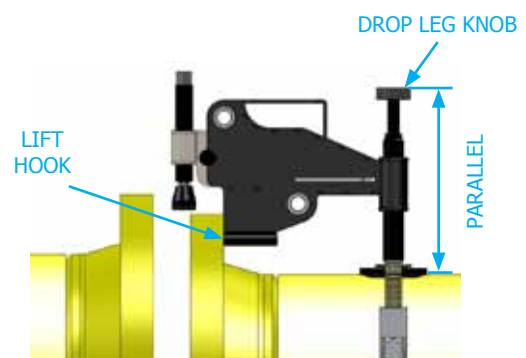
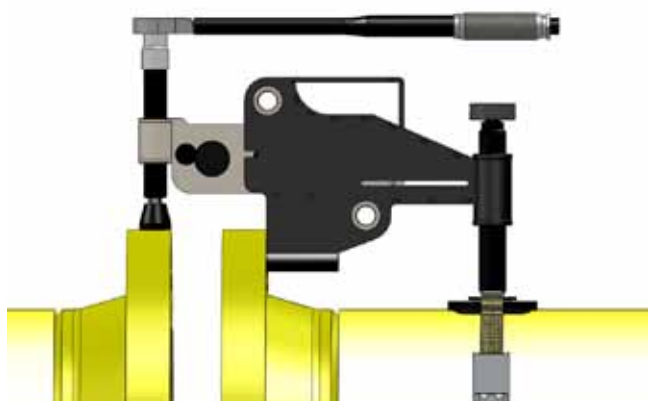

Loosen the wing retaining knob and extend the wing over to the opposite flange.

Rotate the screw bolt onto the surface of the opposite flange. Ensure that the tool is sitting level and that the friction pad on the base of the swivel is in full and even contact with the surface of the opposite flange.

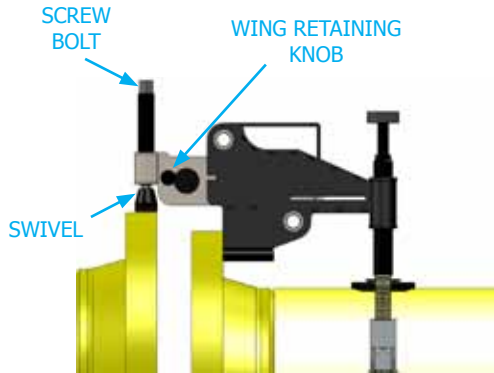

Feed the open end of the strap through the ratchet mechanism as shown. Tighten the strap using the ratchet mechanism.

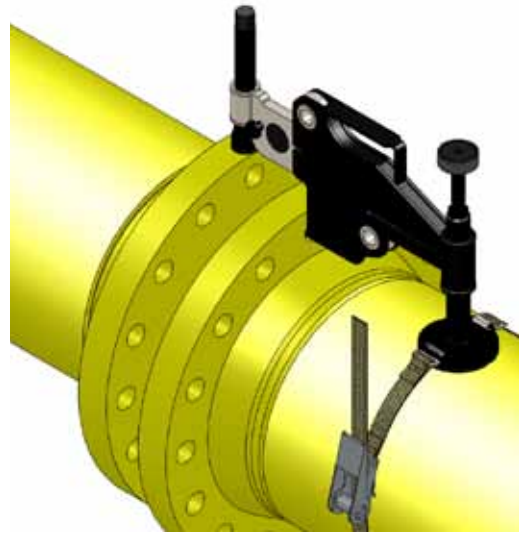

Attach the hook of the strap through the buckle on top of the base plate as shown.

The torque wrench should be set at 19 N·m (14 ft·lb) then attached to the screw bolt.

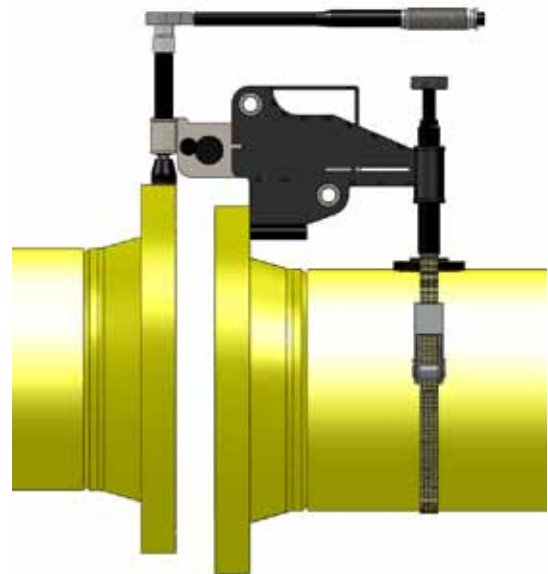

Now place the hook of the ratchet mechanism through the opposite side of the buckle as shown.



Tighten the screw bolt in a clockwise direction until the flanges come into alignment or the torque wrench “clicks”.

If the torque wrench has clicked and the flanges are still misaligned adjust the torque wrench up to 33 N·m (24 ft·lb) and continue until a maximum torque wrench setting of 68 N·m (50 ft·lb) is reached or the flanges are aligned.

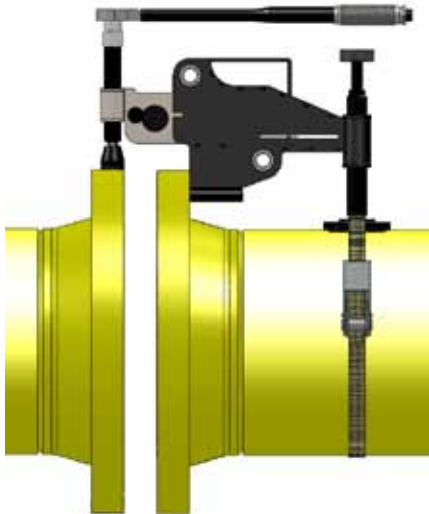

Once in alignment the bolts may be inserted and tightened.

After replacing all of the bolts (apart from the bolt which will go into the bolt-hole in which the FA4TM is located), remove the tool by reversing steps 2 - 8.

Insert the last bolt and tighten.



WARNING: The maximum safe working load is 68 N·m (50 ft·lb). Exceeding 68 N·m (50 ft·lb) will result in damage to the tool.



WARNING: Care should be taken not to drop any of the component parts when removing them from the flange joint. This action will prevent injuries to either the operator’s lower limbs or to passers-by.

4.4

FA4TM KIT CONTENTS

STANDARD KIT

Product Code: FA4TMSTD

- 1 x FA4TM Tool
- 1 x 68 N·m (50 ft·lb) Torque Wrench with 22 mm socket
- 1 x Ratchet and Strap
- 1 x Instruction Manual
- 1 x Carry-Case



Carry-Case Dimensions:

600 mm x 370 mm x 200 mm
(23.6" x 14.6" x 7.9")

Tool only Weight: 8.6 kg (19.0 lb)

Gross Kit Weight: 12.2 kg (26.9 lb)

4.5 FA4TM TOOL DIMENSIONS

MINIMUM EXTENSION

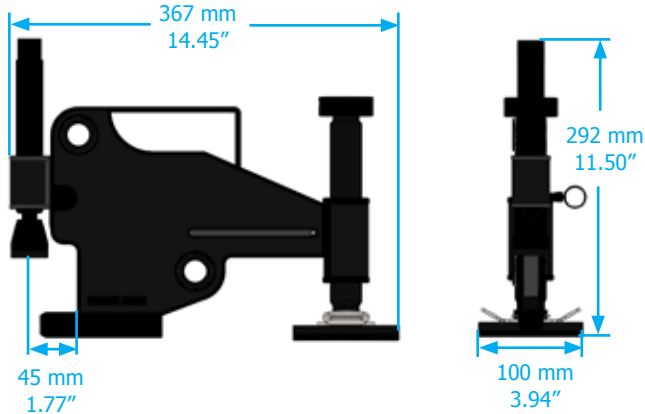

MAXIMUM EXTENSION

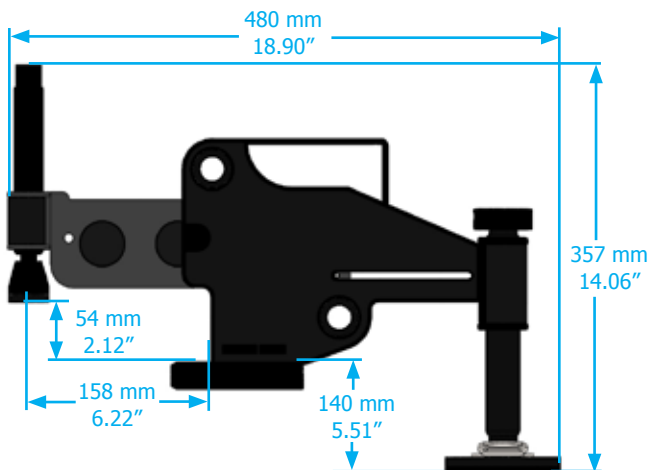

4.6 FA4TM TOOL MAINTENANCE

INSPECTION

A thorough inspection should be carried out prior to usage, storage or transportation to ensure the completeness and condition of the tool.

Inspection should include:

- visual inspection of the outer parts of the tool, checking for obvious damage, degradation or missing parts.
- visual inspection of the swivel, screw bolt and leg screw, checking for obvious damage and degradation.

Cleaning and servicing should be undertaken as required prior to the tool being used, stored or transported.

CLEANING

To lightly clean the tool, wipe gently with a damp cloth.

If more thorough cleaning is required (for example following immersion in water) carry out the following cleaning procedure:

- strip the tool down, observing the schematics in section 9
- clean the components using detergent, following the manufacturer's guidelines
- rinse the components to remove traces of detergent
- dry the component thoroughly

Inspect, service and lubricate the tool immediately after the cleaning process.

SERVICING

Replace missing, worn or damaged parts. Use only genuine Equalizer parts from approved distributors or service centres. Equalizer parts have been engineered and manufactured to be fit for purpose.

Grease all moving parts by following the Lubrication Procedure prior to usage, storage or transportation.

Ensure rollers, pins and wing remain grit free and that the rollers rotate freely.

Secure the tool upright on a bench.

Using a small flat screw driver, lever out the end of the spiral clips and then rotate anti-clockwise and remove.

Slide the roller shafts out in order to remove the rollers and bearings for examination.

Inspect the roller shafts, rollers and bearings for damage. If there is no damage present then they can be cleaned, greased and re-assembled by reversing the steps above.

Recommended grease: Hi-load bearing grease, e.g. Rocol Sapphire hi-load.

It is important that the thrust bearing is free from dirt and corrosion and rotates freely.

With the use of a penetrating oil such as WD-40 or similar, spray the oil between the thrust plate and the swivel as shown below.

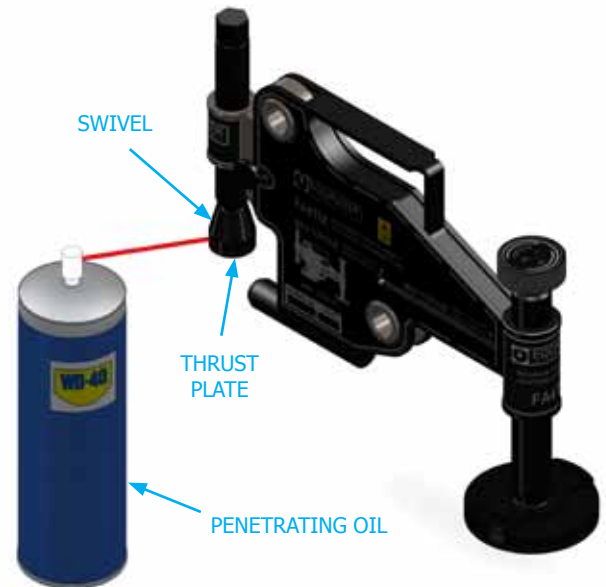

Ensure the thrust plates rotate freely before using the tool to align a flange joint.

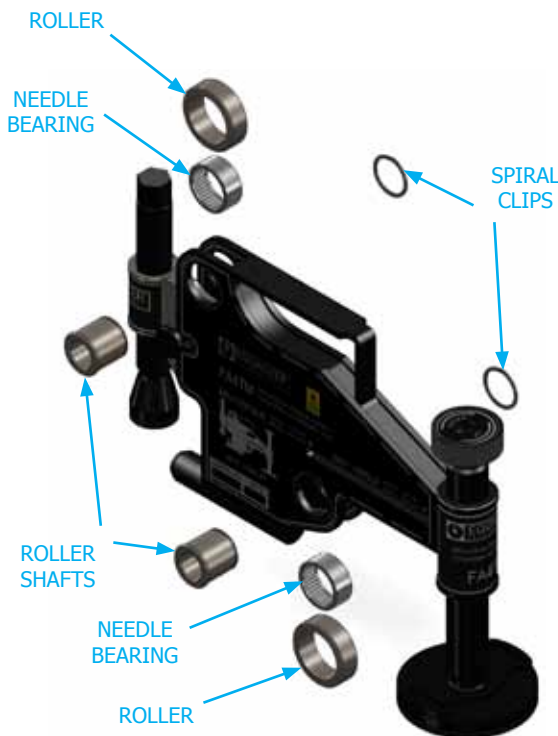

STORAGE AND TRANSPORTATION

Equalizer tools should be stored in a cool, dry place. Tools should always be cleaned, serviced and lubricated prior to storage. Ensure that tools are stored in their designated packing cases.

SUBSEA USAGE

Using FA4TM Sub-Sea:

The FA4TM is actuated mechanically and can be used sub-sea providing the following actions are taken:

- The tool is actuated via the torque wrench by a diver.
- The tool is stripped down, cleaned and lubricated immediately to minimise corrosion.

5.

FA9TE

HYDRAULIC FLANGE ALIGNMENT TOOL



5.1

TOOL CAPABILITIES

ALIGNING FORCE

With 700 bar (10000 psi) of hydraulic pressure applied, the tool can apply 9 T (90 kN) aligning force.

5.2

RANGE OF APPLICATION

Minimum and Maximum Flange sizes:

Dimension A: must be between 93 mm and 228 mm (3.66" and 8.98")

Dimension B: bolt-hole diameter must be 35.5 mm (1.40") or greater

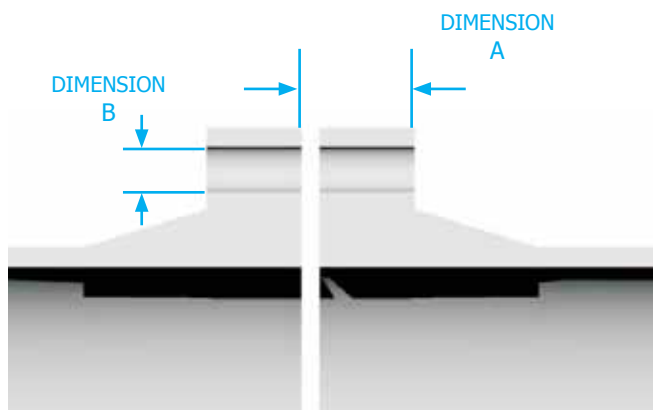

5.3

FA9TE TOOL FUNCTION

FA9TE GENERAL GUIDANCE

The FA9TE is secured to the lower of the two flanges by fully inserting the lift hook into the bolt-hole at the point of greatest misalignment.

The drop leg is adjusted down onto the pipe while the tool is held up level in the bolt hole.

The release knob should be loosened to allow the wing to be extended out to the required distance.

The hydraulic cylinder should then be adjusted down onto the circumference of the flange opposite by rotating it in a clockwise direction.

The hydraulic hose and pump are attached to the cylinder and the hand pump is primed, bringing the joint into alignment.

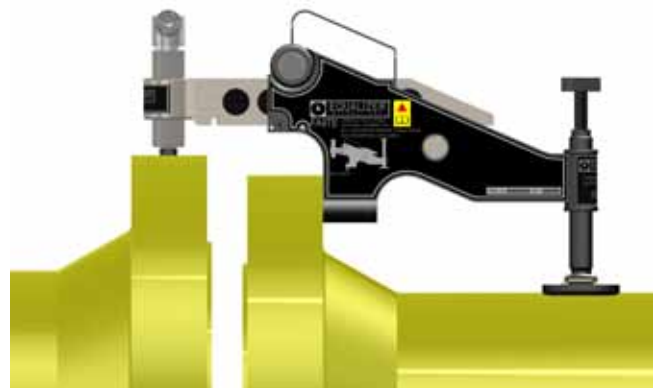

ACTUATING THE FA9TE

Carry out the Flange Misalignment Determination Procedure (see Section 3) to determine the points of maximum misalignment.

In this example the points of maximum misalignment are at the top and bottom of the joint.

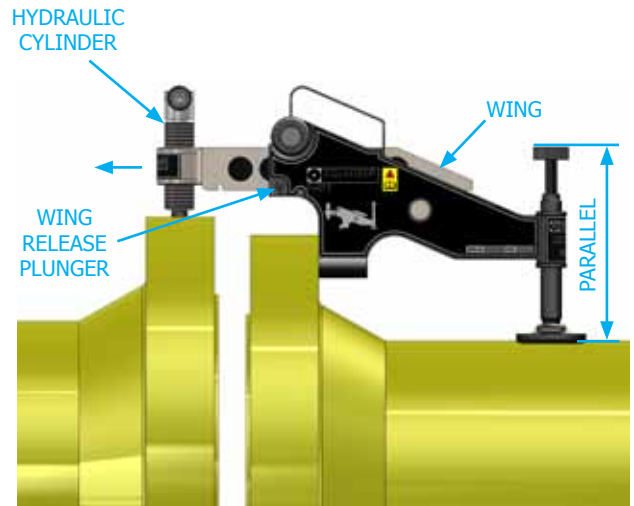
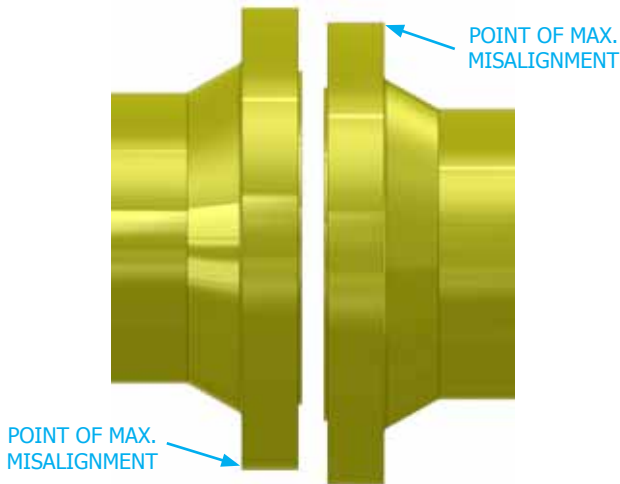

Attach the hook on the strap through the base plate as shown.



Now place the hook of the ratchet mechanism through the base on the opposite side as shown.



Guide the lift hook into the bolt hole at the point of maximum misalignment.

Adjust the drop leg onto the pipe (using the adjustment knob) while holding the lift hook up level with the bolt hole.

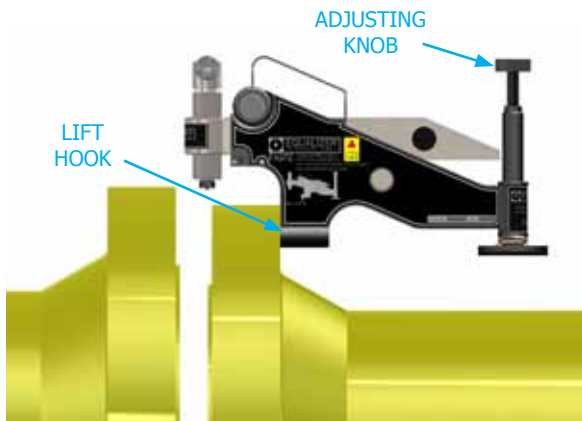

Loosen the wing release knob and extend the wing out to the required distance.

Rotate the hydraulic cylinder down until the base of the cylinder locates onto the surface of the opposite flange.

Ensure that the tool is sitting level and that the cylinder is in full and even contact with the surface of the opposite flange.

N.B Ensure the tool is parallel to the pipe.

Feed the open end of the strap through the ratchet mechanism as shown. Tighten the strap using the ratchet mechanism.



Connect the hydraulic pump to the hydraulic hose, and the hose to the hydraulic adjusting cylinder.

Prime the pump until the joint comes into alignment.



Once in alignment the bolts may be inserted and tightened.

After replacing all of the bolts (apart from the bolt which will go into the bolt hole in which the FA9TE is located), remove the tool by reversing the steps above.

Insert the last bolt and tighten.



WARNING: Care should be taken not to drop any of the component parts when removing them from the flange joint. This action will prevent injuries to either the operator's lower limbs or to passers-by.

5.4 FA9TE KIT CONTENTS

STANDARD KIT

Product Code: FA9TESTD

- 1 x FA9TE Tool
- 1 x 700 bar (10 000 psi) HP350S Hydraulic Hand Pump
- 1 x 2.0 m (78.74"), 700 bar (10 000 psi) Hydraulic Hose
- 1 x Ratchet and Strap
- 1 x Instruction Manual
- 1 x Carry-Case



Carry-Case Dimensions:

920 mm x 520 mm x 210 mm
(36.2" x 20.5" x 8.3")

Tool only Weight: 14.5 kg (32.0 lb)

Gross Kit Weight: 26.5 kg (58.4 lb)

5.5 FA9TE TOOL DIMENSIONS

MINIMUM EXTENSION

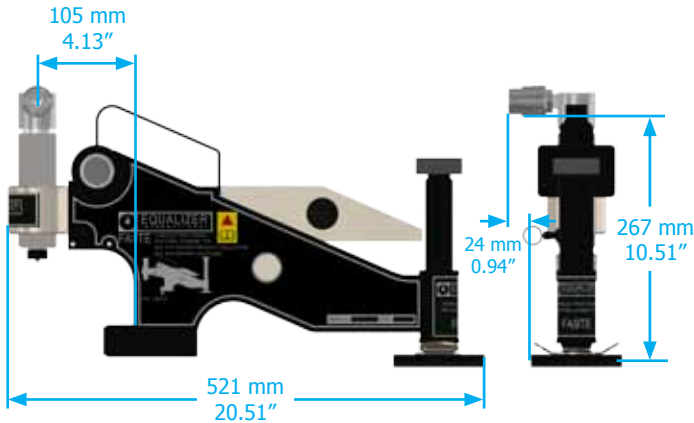

MAXIMUM EXTENSION

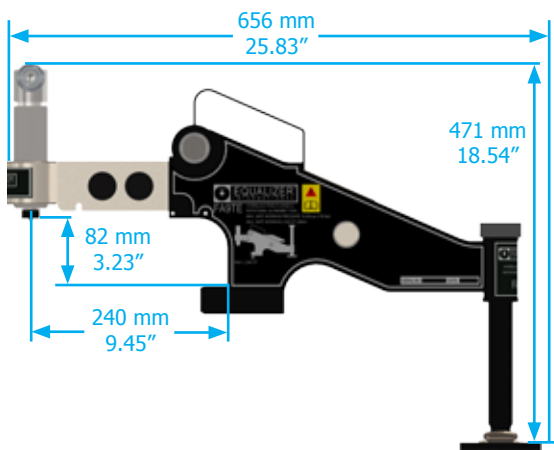

5.6 FA9TE TOOL MAINTENANCE

INSPECTION

A thorough inspection should be carried out prior to usage, storage or transportation to ensure the completeness and condition of the tool.

Inspection should include:

- visual inspection of the outer parts of the tool, checking for obvious damage, degradation or missing parts.
- visual inspection of the hydraulic cylinder, hydraulic coupler and leg screw, checking for obvious damage and degradation.

Cleaning and servicing should be undertaken as required prior to the tool being used, stored or transported.

CLEANING

To lightly clean the tool, wipe gently with a damp cloth.

If more thorough cleaning is required (for example following immersion in water) carry out the following cleaning procedure:

- strip the tool down, observing the schematics in section 9
- clean the components using detergent, following the manufacturer's guidelines
- rinse the components to remove traces of detergent
- dry the component thoroughly

Inspect, service and lubricate the tool immediately after the cleaning process.

SERVICING

Replace missing, worn or damaged parts. Use only genuine Equalizer parts from approved distributors or service centres. Equalizer parts have been engineered and manufactured to be fit for purpose.

Grease all moving parts by following the Lubrication Procedure prior to usage, storage or transportation.

Ensure rollers, pins and wing remain grit free and that the rollers rotate freely.

Place the tool on a workbench and secure it in an upright position.

Remove the two spring pins on the front of the main body as shown.

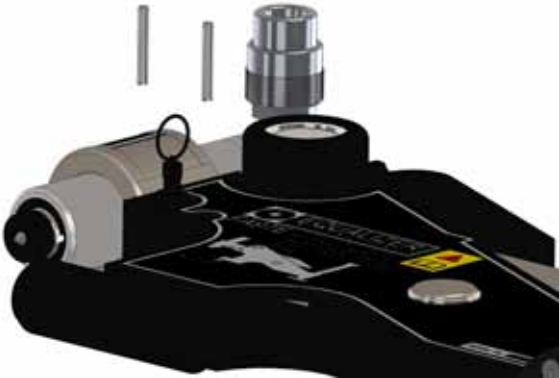

The wing can now be removed from the main body by sliding it forward.



Remove the circlip using circlip pliers (not illustrated).



Remove the shaft and two bearings.

Inspect the bearing housing, shaft and needle bearings for any sign of damage, dirt or grit. Clean the surfaces before applying grease to the shaft and into the needle bearings.

Recommended grease - Rocol or Sapphire Hi-Load.



Remove the spirol retaining clips from the lower shaft and slide the shaft out from the main body.

The roller and needle bearing can be removed through the upper section of the tool as shown.

Inspect the roller, shaft and needle bearings for any sign of damage, dirt or grit. Clean and then smear a small amount of grease onto the shaft and into the needle bearings.

Recommended grease - Rocol Sapphire Hi-Load or equivalent Hi-Load Bearing grease.

Re-assemble by reversing the steps above.

STORAGE AND TRANSPORTATION

Equalizer tools should be stored in a cool, dry place. Tools should always be cleaned, serviced and lubricated prior to storage. Ensure that tools are stored in their designated packing cases.

SUBSEA USAGE

Using FA9TE Sub-Sea:

The FA9TE is actuated by means of single acting spring-return hydraulic cylinder and can be used subsea providing the following actions are taken:

- The gauge and manifold are removed from the Equalizer hydraulic hand pump and the coupler is fitted directly to the pump outlet (tools in this configuration can be requested from Equalizer).
- The tool is connected to the Equalizer pump while still top-side.
- The pump release valve is fully opened and remains open until the tool has descended to the working depth. This will allow the pressure to equalise.
- The tool is actuated via the hand pump by a diver.
- Upon completion of works the release valve is left in the fully open position until the tool has ascended to the surface.

Please note that a sub-sea FA9TE tool cannot be operated from top-side by use of a down-line. The return springs in the hydraulic cylinders do not have sufficient force to close the tool if used with a down-line from a top-side pump, therefore the standard hydraulic tools will not function correctly and may jam in place if used in this configuration.

6 RANGE OF APPLICATION

6.1 BS10 FLANGE RANGE OF APPLICATION

CLASS A	CLASS D	CLASS E	CLASS F	CLASS H	CLASS J	CLASS K	CLASS R	CLASS S	CLASS T
NPS 3 1/2"	4"	1 1/4"	1 1/4"	1 1/4"	1 1/4"	1"	1"	1/2"	1/2"
4"	5"	1 1/2"	1 1/2"	1 1/2"	1 1/2"	1 1/4"	1 1/4"	3/4"	3/4"
5"	6"	2"	2"	2"	2"	1 1/2"	1 1/2"	1"	1"
6"	7"	2 1/2"	2 1/2"	2 1/2"	2 1/2"	2"	2"	1 1/4"	1 1/4"
7"	8"	3"	3"	3"	3"	2 1/2"	2 1/2"	1 1/2"	1 1/2"
8"	9"	3 1/2"	3 1/2"	3 1/2"	3 1/2"	3"	3"	2"	2"
9"	10"	4"	4"	4"	4"	3 1/2"	3 1/2"	2 1/2"	2 1/2"
10"	12"	5"	5"	5"	5"	4"	4"	3"	3"
12"	13"	6"	6"	6"	6"	5"	5"	3 1/2"	3 1/2"
13"	14"	7"	7"	7"	7"	6"	6"	4"	4"
14"	15"	8"	8"	8"	8"	7"	7"	4 1/2"	4 1/2"
15"	16"	9"	9"	9"	9"	8"	8"	5"	5"
16"	17"	10"	10"	10"	10"	9"	9"	6"	6"
17"	18"	12"	12"	12"	12"	10"	10"	7"	7"
18"	19"	13"	13"	13"	13"	12"	12"	8"	8"
19"	20"	14"	14"	14"	14"	13"	13"	9"	9"
20"	21"	15"	15"	15"	15"	14"	14"	10"	10"
21"	22"	16"	16"	16"	16"	15"	15"	11"	11"
22"	23"	17"	17"	17"	17"	16"	16"	12"	12"
23"	24"	18"	18"	18"	18"	17"	17"	13"	13"
24"	26"	19"	19"	19"	19"	18"	18"		
26"	27"	20"	20"	20"	20"	19"	19"		
27"	29"	21"	21"	21"	21"	20"	20"		
29"	30"	22"	22"	22"	22"	21"	21"		
30"	33"	23"	23"	23"	23"	22"	22"		
33"	35"	24"	24"	24"	24"	23"	23"		
35"	36"	25"	25"	25"	25"	24"	24"		
36"	39"	27"	27"	27"	27"	26"	26"		
39"	42"	29"	29"	29"	29"	27"	27"		
42"	45"	30"	30"	30"	30"	28"	28"		
45"	48"	33"	33"	33"	33"	30"	30"		
48"	54"	35"	35"	35"	35"	33"	33"		
54"	60"	36"	36"	36"	36"	35"	35"		
60"	66"	39"	39"	39"	39"	39"	39"		
66"	72"	42"	42"	42"	42"	42"	42"		
72"	78"	45"	45"	45"	45"	45"	45"		
78"	84"	48"	48"	48"	48"	48"	48"		
84"	96"	54"	54"	54"	54"	54"	54"		
96"	108"	60"	60"	60"	60"	60"	60"		
108"	120"	66"	66"	66"	66"	66"	66"		
		72"	72"	72"	72"	72"	72"		
		78"	78"	78"	78"	78"	78"		
		84"	84"	84"	84"	84"	84"		
		96"	96"	96"	96"	96"	96"		
		108"	108"	108"	108"	108"	108"		
		120"	120"	120"	120"	120"	120"		

SUITABLE FOR FA1TM TOOL
 SUITABLE FOR FA4TM TOOL
 SUITABLE FOR FA9TE TOOL
 NOT SUITABLE FOR TOOLS

API6B WELD NECK FLANGE RANGE OF APPLICATION

CLASS 10K	CLASS 15K	CLASS 20K
NPS 1 1/2"	1 1/2"	1 1/2"
2"	2"	2"
2 1/2"	2 1/2"	2 1/2"
3"	3"	3"
3 1/2"	3 1/2"	3 1/2"
4"	4"	4"
4 1/2"	4 1/2"	4 1/2"
5"	5"	5"
5 1/2"	5 1/2"	5 1/2"
6"	6"	6"
6 1/2"	6 1/2"	6 1/2"
7"	7"	7"
7 1/2"	7 1/2"	7 1/2"
8"	8"	8"
8 1/2"	8 1/2"	8 1/2"
9"	9"	9"
9 1/2"	9 1/2"	9 1/2"
10"	10"	10"
10 1/2"	10 1/2"	10 1/2"
11"	11"	11"
11 1/2"	11 1/2"	11 1/2"
12"	12"	12"
12 1/2"	12 1/2"	12 1/2"
13"	13"	13"
13 1/2"	13 1/2"	13 1/2"
14"	14"	14"
14 1/2"	14 1/2"	14 1/2"
15"	15"	15"
15 1/2"	15 1/2"	15 1/2"
16"	16"	16"
16 1/2"	16 1/2"	16 1/2"
17"	17"	17"
17 1/2"	17 1/2"	17 1/2"
18"	18"	18"
18 1/2"	18 1/2"	18 1/2"
19"	19"	19"
19 1/2"	19 1/2"	19 1/2"
20"	20"	20"

API6B WELD NECK FLANGE RANGE OF APPLICATION

CLASS 2K	CLASS 3K	CLASS 5K
NPS 2 1/2"	2 1/2"	2 1/2"
3"	3"	3"
3 1/2"	3 1/2"	3 1/2"
4"	4"	4"
4 1/2"	4 1/2"	4 1/2"
5"	5"	5"
5 1/2"	5 1/2"	5 1/2"
6"	6"	6"
6 1/2"	6 1/2"	6 1/2"
7"	7"	7"
7 1/2"	7 1/2"	7 1/2"
8"	8"	8"
8 1/2"	8 1/2"	8 1/2"
9"	9"	9"
9 1/2"	9 1/2"	9 1/2"
10"	10"	10"
10 1/2"	10 1/2"	10 1/2"
11"	11"	11"
11 1/2"	11 1/2"	11 1/2"
12"	12"	12"
12 1/2"	12 1/2"	12 1/2"
13"	13"	13"
13 1/2"	13 1/2"	13 1/2"
14"	14"	14"
14 1/2"	14 1/2"	14 1/2"
15"	15"	15"
15 1/2"	15 1/2"	15 1/2"
16"	16"	16"
16 1/2"	16 1/2"	16 1/2"
17"	17"	17"
17 1/2"	17 1/2"	17 1/2"
18"	18"	18"
18 1/2"	18 1/2"	18 1/2"
19"	19"	19"
19 1/2"	19 1/2"	19 1/2"
20"	20"	20"

6.2 ASME B16.5 FLANGE RANGE OF APPLICATION

CLASS	TOOL		TOOL		TOOL		TOOL		TOOL		TOOL		TOOL		TOOL		TOOL		TOOL	
CLASS 150	NPS	3/4"	1"	1 1/4"	1 1/2"	2"	2 1/2"	3"	3 1/2"	4"	5"	6"	8"	10"	12"	14"	16"	18"	20"	24"
		FA1TM																		
CLASS 300	NPS	3/4"	1"	1 1/4"	1 1/2"	2"	2 1/2"	3"	3 1/2"	4"	5"	6"	8"	10"	12"	14"	16"	18"	20"	24"
		FA1TM																		
CLASS 400	NPS	3/4"	1"	1 1/4"	1 1/2"	2"	2 1/2"	3"	3 1/2"	4"	5"	6"	8"	10"	12"	14"	16"	18"	20"	24"
		FA1TM																		
CLASS 600	NPS	3/4"	1"	1 1/4"	1 1/2"	2"	2 1/2"	3"	3 1/2"	4"	5"	6"	8"	10"	12"	14"	16"	18"	20"	24"
		FA1TM																		
CLASS 900	NPS	1/2"	3/4"	1"	1 1/4"	1 1/2"	2"	2 1/2"	3"	4"	5"	6"	8"	10"	12"	14"	16"	18"	20"	24"
		FA4TM																		
CLASS 1500	NPS	1/2"	3/4"	1"	1 1/4"	1 1/2"	2"	2 1/2"	3"	4"	5"	6"	8"	10"	12"	14"	16"	18"	20"	24"
		FA4TM																		
CLASS 2500	NPS	1/2"	3/4"	1"	1 1/4"	1 1/2"	2"	2 1/2"	3"	4"	5"	6"	8"	10"	12"	14"	16"	18"	20"	24"
		FA4TM																		

ASME B16.47 FLANGE RANGE OF APPLICATION

CLASS	TOOL		TOOL		TOOL		TOOL		TOOL		TOOL		TOOL		TOOL		TOOL		TOOL	
CLASS 150	NPS	22"	26"	28"	30"	32"	34"	36"	38"	40"	42"	44"	46"	48"						
		FA4TM																		
CLASS 300	NPS	22"	26"	28"	30"	32"	34"	36"	38"	40"	42"	44"	46"	48"						
		FA4TM																		
CLASS 400	NPS	22"	26"	28"	30"	32"	34"	36"	38"	40"	42"	44"	46"	48"						
		FA4TM																		
CLASS 600	NPS	22"	26"	28"	30"	32"	34"	36"	38"	40"	42"	44"	46"	48"						
		FA4TM																		
CLASS 900	NPS	22"	26"	28"	30"	32"	34"	36"	38"	40"	42"	44"	46"	48"						
		FA9TE																		

DIN WELD NECK FLANGE RANGE OF APPLICATION

CLASS	TOOL		TOOL		TOOL		TOOL		TOOL		TOOL		TOOL		TOOL		TOOL		TOOL	
CLASS PN16	NPS	1 1/2"	2"	2 1/2"	3"	4"	5"	6"	7"	8"	10"	12"	14"	16"	18"	20"	24"	28"	32"	36"
		FA1TM																		
CLASS PN25	NPS	1/2"	3/4"	1"	1 1/4"	1 1/2"	2"	2 1/2"	3"	4"	5"	6"	7"	8"	10"	12"	14"	16"	18"	20"
		FA1TM																		
CLASS PN40	NPS	1 1/2"	2"	2 1/2"	3"	4"	5"	6"	7"	8"	10"	12"	14"	16"	18"	20"				
		FA1TM																		
CLASS PN64	NPS	3/4"	1"	1 1/2"	2"	2 1/2"	3"	4"	5"	6"	7"	8"	10"	12"	14"	16"				
		FA1TM																		
CLASS PN100	NPS	1/2"	3/4"	1"	1 1/2"	2"	2 1/2"	3"	4"	5"	6"	7"	8"	10"	12"	14"				
		FA1TM																		
CLASS PN160	NPS	3/8"	1/2"	3/4"	1"	1 1/2"	2"	2 1/2"	3"	4"	5"	6"	7"	8"	10"	12"				
		FA1TM																		

	SUITABLE FOR FA1TM TOOL
	SUITABLE FOR FA4TM TOOL
	SUITABLE FOR FA9TE TOOL
	NOT SUITABLE FOR TOOLS

6.3 SPO FLANGE RANGE OF APPLICATION

CLASS	TOOL		RANGE OF APPLICATION																									
CLASS 150	NPS	2 1/2"	3"	3 1/2"	4"	5"	6"	8"	10"	12"	14"	16"	18"	20"	22"	24"	26"	28"	30"	32"	34"	36"	38"	40"	42"	44"	46"	48"
		TOOL	FA1TM																									
CLASS 300	NPS	2 1/2"	3"	3 1/2"	4"	5"	6"	8"	10"	12"	14"	16"	18"	20"	22"	24"	26"	28"	30"	32"	34"	36"	38"	40"	42"	44"	46"	48"
		TOOL	FA1TM												FA4TM												FA9TE	
CLASS 600	NPS	2 1/2"	3"	3 1/2"	4"	5"	6"	8"	10"	12"	14"	16"	18"	20"	22"	24"	26"	28"	30"	32"	34"	36"	38"	40"	42"	44"	46"	48"
		TOOL	FA4TM												FA9TE													
CLASS 900	NPS	2 1/2"	3"	3 1/2"	4"	5"	6"	8"	10"	12"	14"	16"	18"	20"	22"	24"	26"	28"	30"	32"	34"	36"	38"	40"	42"	44"	46"	48"
		TOOL	FA4TM												FA9TE													
CLASS 1500	NPS	2 1/2"	3"	3 1/2"	4"	5"	6"	8"	10"	12"	14"	16"	18"	20"	22"	24"	FA9TE											
		TOOL	FA4TM												FA9TE													
CLASS 2500	NPS	2 1/2"	3"	3 1/2"	4"	5"	6"	8"	10"	12"	14"	16"	18"	20"	22"	24"	FA9TE											
		TOOL	FA4TM												FA9TE													
CLASS 5000	NPS	2 1/2"	3"	3 1/2"	4"	5"	6"	8"	10"	12"	14"	16"	18"	20"	22"	24"	FA9TE											
		TOOL	FA4TM												FA9TE													
CLASS 7500	NPS	2 1/2"	3"	3 1/2"	4"	5"	6"	8"	10"	12"	14"	16"	18"	20"	22"	24"	FA9TE											
		TOOL	FA4TM												FA9TE													
CLASS 10000	NPS	2 1/2"	3"	3 1/2"	4"	5"	6"	8"	10"	12"	14"	16"	18"	20"	22"	24"	FA9TE											
		TOOL	FA4TM												FA9TE													
CLASS 15000	NPS	2 1/2"	3"	3 1/2"	4"	5"	6"	8"	10"	12"	14"	16"	18"	20"	22"	24"	FA9TE											
		TOOL	FA4TM												FA9TE													

SUITABLE FOR FA1TM TOOL
SUITABLE FOR FA4TM TOOL
SUITABLE FOR FA9TE TOOL
NOT SUITABLE FOR TOOLS

7.

TROUBLESHOOTING

7.1

FA4TM TROUBLESHOOTING

THE THRUST PLATE IS SLIDING ALONG THE CIRCUMFERENCE OF THE OPPOSITE FLANGE AS THE TOOL IS ALIGNING THE JOINT

POSSIBLE CAUSE:

Grit or dirt on wing, rollers or bearings.

RECOMMENDED ACTION:

Ensure the rollers are rotating freely and that there is no restrictions to the rollers on the wing surfaces such as grit or dirt.

POSSIBLE CAUSE:

Wing is at full extension.

RECOMMENDED ACTION:

Ensure the wing has sufficient travel left in order to allow the joint to align.

THE TOOL IS ATTACHED AND APPEARS TO BE FUNCTIONING PROPERLY, BUT THE JOINT WILL NOT ALIGN

POSSIBLE CAUSE:

There may be something restricting the joint from aligning.

RECOMMENDED ACTION:

Check the area around the joint to establish if there is an obstruction to the joint.

POSSIBLE CAUSE:

The joint may require more than 4 T (40 kN) force to align.

RECOMMENDED ACTION:

If the joint requires more force than that of the 4 T (40 kN) tool, then another method of alignment should be adopted.

THE THRUST PLATE IS TWISTING ON THE CIRCUMFERENCE OF THE FLANGE WHEN THE SCREW BOLT IS TIGHTENED

POSSIBLE CAUSE:

There may be grit or dirt within the swivel / thrust plate.

RECOMMENDED ACTION:

Check that the thrust plate rotates freely. If the thrust plate is not rotating then spray some penetrating liquid into the gap between the swivel and thrust plate in order to loosen it.

7.2

FA9TE TROUBLESHOOTING

THE TOOL IS ADVANCING BUT DOES NOT REACH FULL PRESSURE

POSSIBLE CAUSE:

Air could be present in the hydraulic system.

RECOMMENDED ACTION:

Use the airlock removal procedure as follows:

Connect the hand pump to the tool with the hydraulic hose.

Close the release valve on the pump and prime the pump until the hydraulic cylinder is fully extended and a small pressure is achieved.

With the hand pump held above the tool in an upright position, open the release valve. Any air that is within the system will be forced up through the pump and vented into the oil reservoir.

Repeat the above steps three or four times to ensure that all air is removed from the system and the tool will reach full working pressure.

Disconnect the hand pump from the hydraulic hose, grip the baseplate of the hand pump body in a vice with the pump body vertical and the main handle at the top.

Remove the four nuts holding the main handle and lift off.

Grip the refilling plug with pliers and extract it by pulling and twisting simultaneously. Ensure the reservoir body is held down when removing the refilling plug as pulling up on the reservoir body will release the bladder within, and oil will spill out.

Fill the reservoir to the top with a good quality hydraulic oil of the grade 15 cSt.

Reinsert the refilling plug, wipe away any oil and reassemble by reversing the disassembly process.

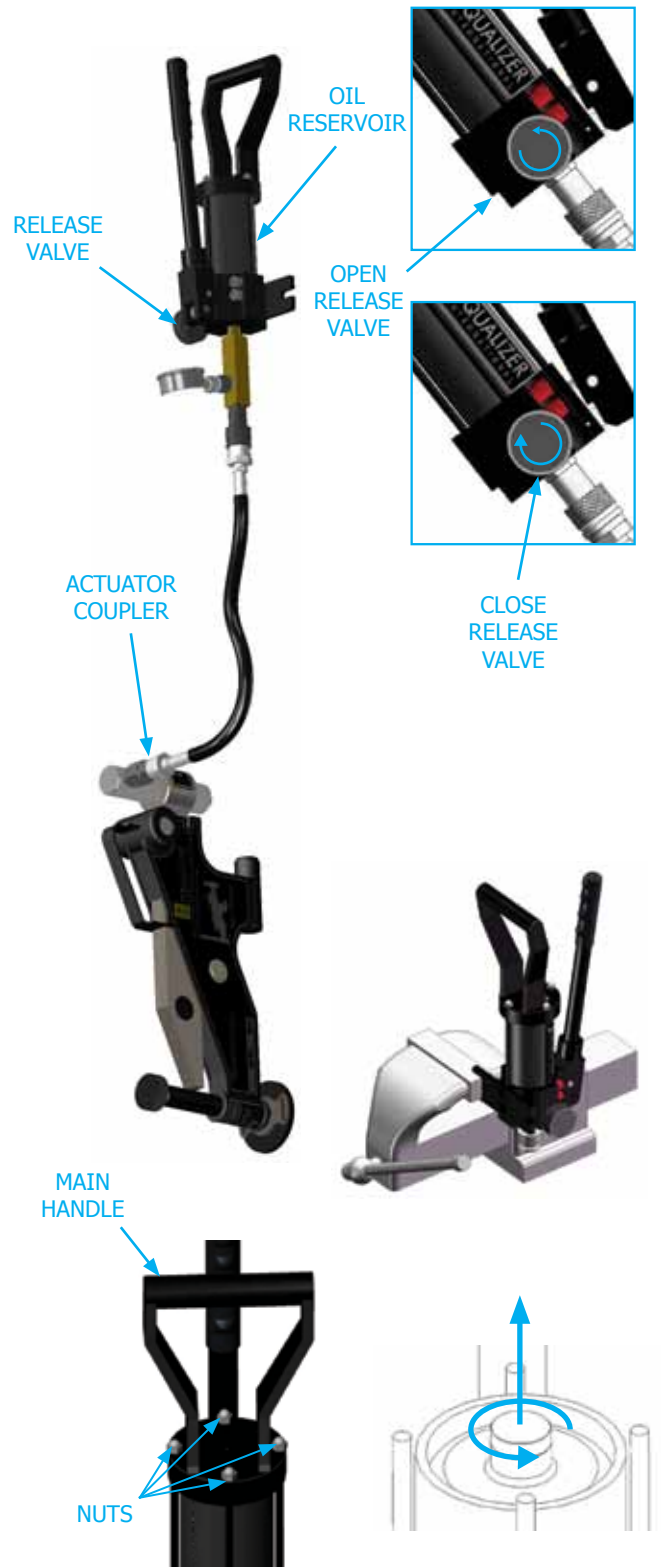

THE FRICTION PAD IS SLIDING IN THE CIRCUMFERENCE OF THE OPPOSITE FLANGE AS THE TOOL IS ALIGNING THE JOINT

POSSIBLE CAUSE:

Grit or dirt on wing, rollers or bearings.

RECOMMENDED ACTION:

Ensure the rollers are rotating freely and that there is no restriction to the rollers on the wing surfaces such as dirt or grit.

POSSIBLE CAUSE:

Wing is at full extension.

RECOMMENDED ACTION:

Check that the wing is not at full extension when aligning the joint. Ensure that there is enough extension left to allow the tool to expand as the joint is aligned.

THE TOOL IS ATTACHED AND APPEARS TO BE FUNCTIONING PROPERLY, BUT THE JOINT WILL NOT ALIGN

POSSIBLE CAUSE:

There may be something restricting the joint at a point close to the flanges.

RECOMMENDED ACTION:

Check the area around the joint to establish if there is an obstruction to the joint.

POSSIBLE CAUSE:

The joint may require more than 9 T (90 kN) force to align.

RECOMMENDED ACTION:

If the joint requires more force than that of the 9 T (90 kN) tool, then another method of aligning the joint should be adopted.

8.

REGULATORY INFORMATION

8.1

REGISTERED HEAD OFFICE

EQUALIZER INTERNATIONAL LTD.
Equalizer House
Claymore Drive
Aberdeen
Scotland
AB23 8GD

9.

PARTS LISTS & SERVICE KITS

FA4TM PARTS LIST

220000-01 REV. 15.1

ITEM NO.	PART NO	DESCRIPTION	QTY
1	400280-01	RATCHET STRAP	1
2	070273-01	DROP LEG KNOB STICKER	1
3	400270-01	RATCHET	1
4	070270-01	BODY PLATE STICKER LEFT	1
5	220700-01	LEG SCREW EXTENSION	1
6	400203-01	TORQUE WRENCH	1
7	400204-01	22 mm SOCKET	1
8	901601-01	SPIROL CLIP	2
9	220100-01	MAIN BODY	1
10	070272-01	EQUALIZER LOGO FOR BOSS	1
11	230802-01	BUCKLE	1
12	220602-01	SPIROL CLIP	1
13	220600-01	LEG SCREW	1
14	230803-09	ROUND BASE PAD PROFILE	1
15	402601-01	CTRS SCREW M6X10	3
16	300401-01	M5 SCKT SET SCREW	1
17	401601-01	OUTER ROLLER	2
18	401501-01	NEEDLE BEARING	2
19	070271-01	BODY PLATE STICKER RIGHT	1
20	220500-01	ROLLER SHAFT	2
21	403201-01	ROLLER PIN	1
22	220400-01	FRICTION PAD	1
23	404701-01	THRUST RACE	1
24	404801-01	THRUST WASHER	2
25	212000-01	SPRING RING 8MM	1
26	220300-01	SWIVEL	1
27	400401-01	SPRING CLIP	1
28	401001-01	SLIDING ARM ASS	1
29	070004-01	LOGO FOR WING	1
30	400301-01	SCREW BOLT	1

FA4TM PARTS LIST

220000-01 REV. 15.1

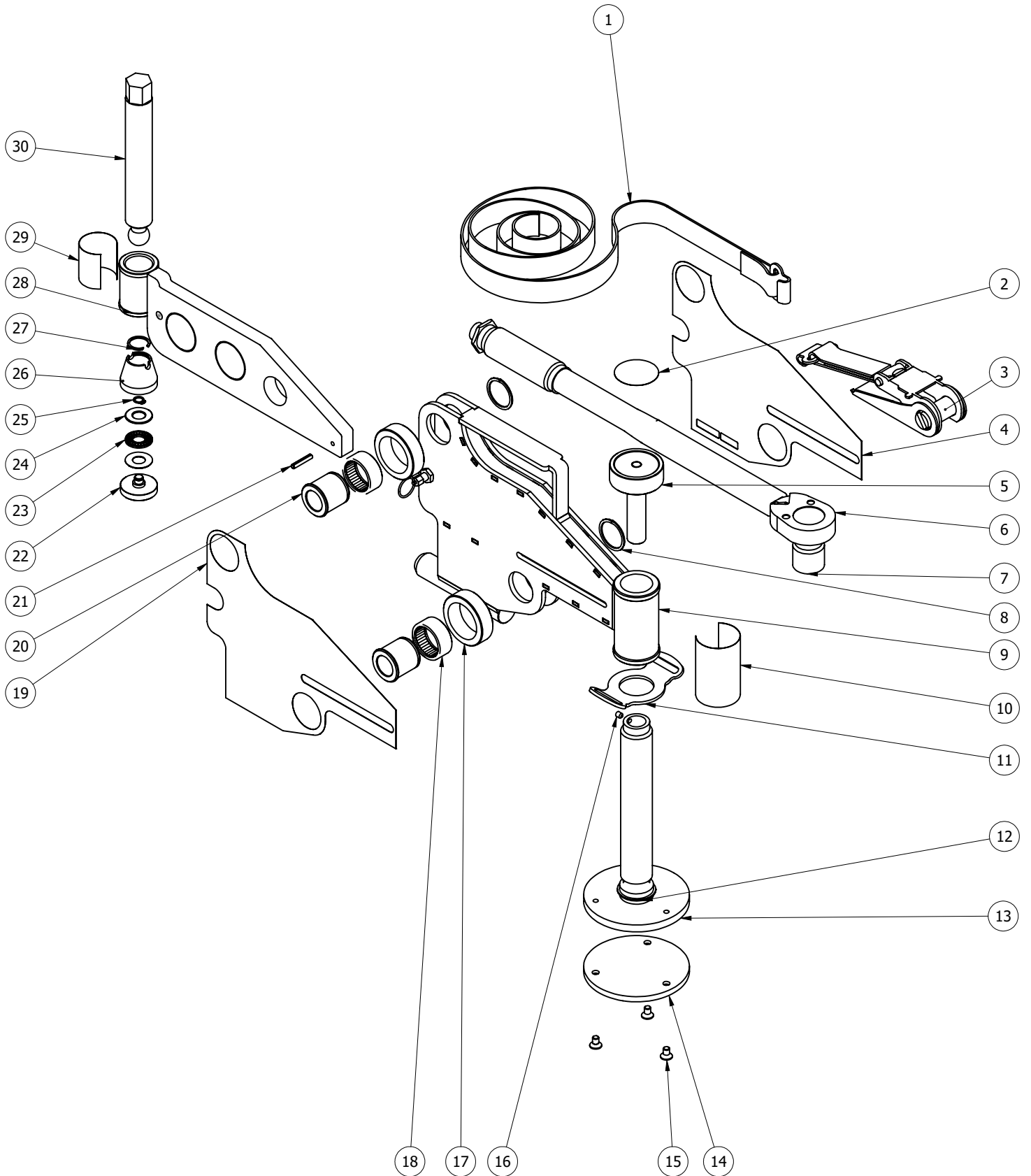

FA9TE PARTS LIST

230000-01 REV. 18

ITEM NO.	PART NO	DESCRIPTION	QTY.	ITEM NO.	PART NO	DESCRIPTION	QTY.
1	230100-01	MAIN BODY	1	13	300401-01	M5 SCKT SET SCREW	1
2	230600-01	NEEDLE BEARING	3	14	220602-01	SPIROL CLIP	1
3	070276-01	FA9TE BODY PLATE STICKER LEFT	1	15	230400-01	REAR ROLLER	1
4	400280-01	RATCHET STRAP	1	16	230500-01	REAR ROLLER PIN	1
5	400270-01	RATCHET	1	17	901601-01	SPIROL CLIP	2
6	070273-01	DROP LEG KNOB STICKER	1	18	070277-01	FA9TE BODY PLATE STICKER RIGHT	1
7	220700-01	LEG SCREW EXTENSION	1	19	230112-01	SPRING PIN 5X36	2
8	070278-01	EQUALIZER LOGO FOR BOSS	1	20	230700-01	CIRCLIP O/D 40	2
9	230802-01	BUCKLE	1	21	230300-01	FRONT ROLLER PIN	1
10	400901-01	CTRS SCRW M6X14	3	22	230200-01	WING ARM (WELDMENT)	1
11	230803-09	ROUND BASE PAD PROFILE	1	23	070233-01	LOGO FOR WING	1
12	220600-01	LEG SCREW	1	24	903101-01	6T H. CYLINDER (PR601UK)	1

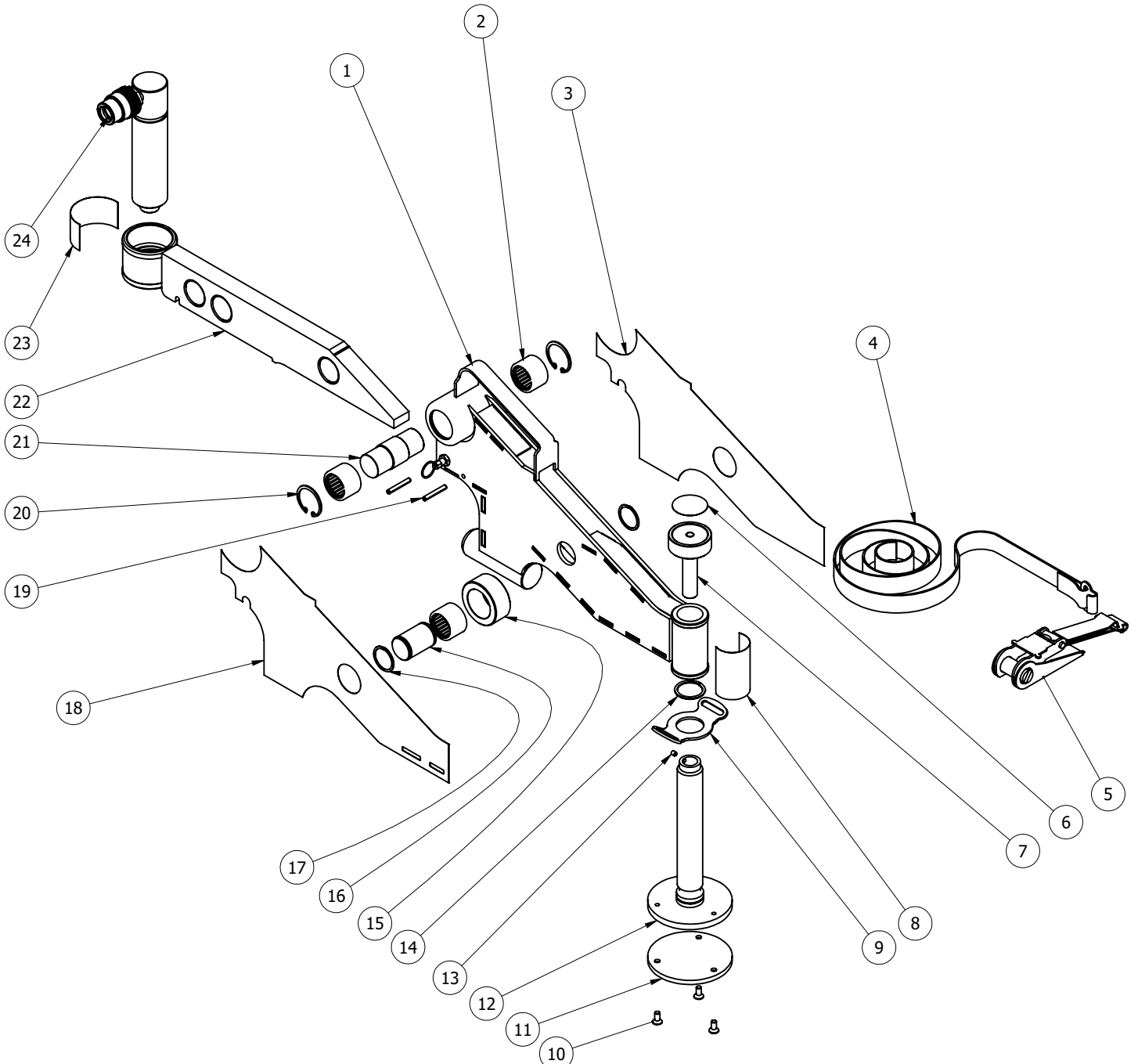



EQUALIZER INTERNATIONAL LTD.

**Head Office
Equalizer House
Claymore Drive
Aberdeen
Scotland
UK
AB23 8GD
t: +44 (0) 1224 701970
f: +44 (0) 1224 823791**

**Houston Office
1330 Yale Street
Houston TX 77008
USA
t: +1 (713) 927-1840**

www.equalizerinternational.com